

## PLANT FOR JOINING PS20

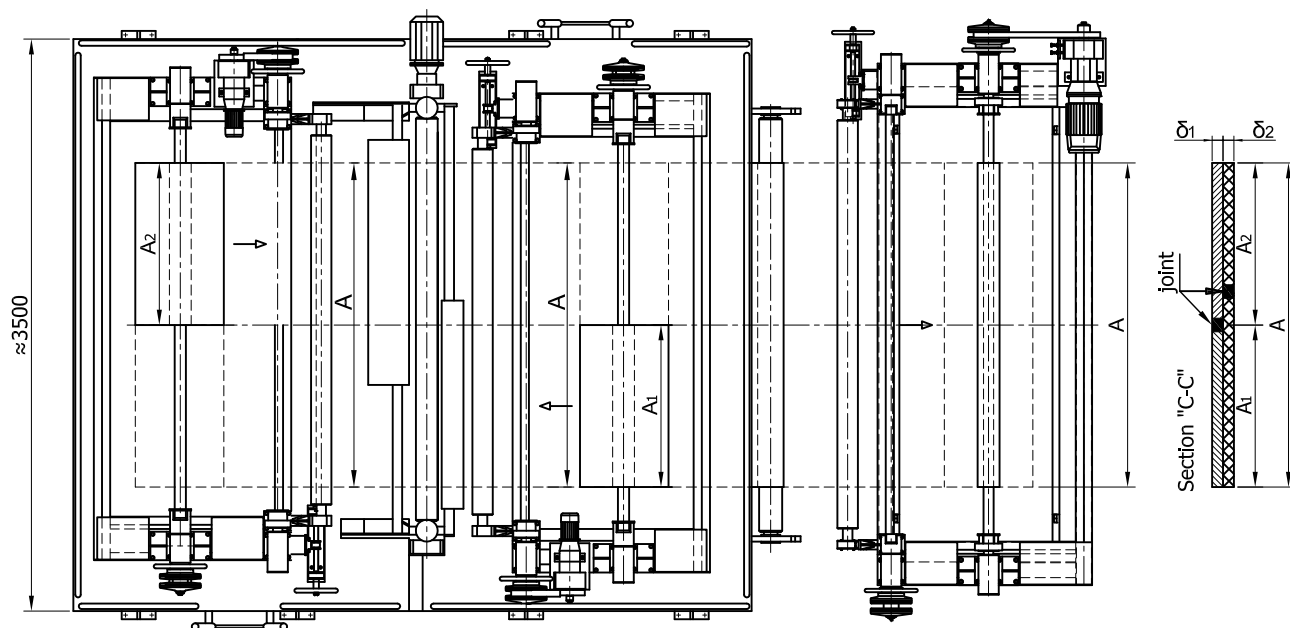
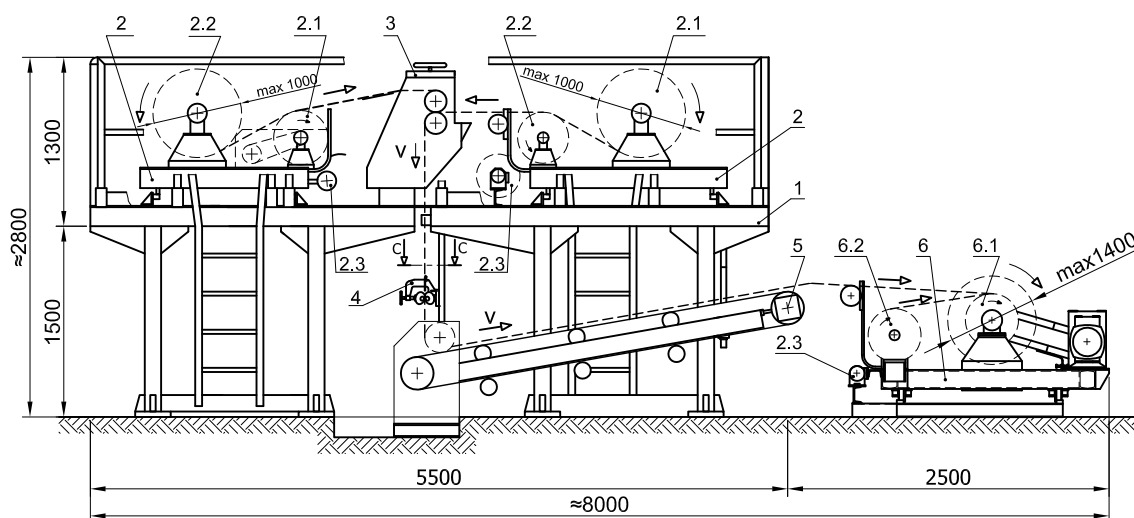

### Legend:

1. Frame
2. Unwinding station
  - 2.1 Unwinding of rubber canvas/rubber lining
  - 2.2 Winding of lining
- 2.3 Drive cart
3. Dubling roler
4. Joining mechanism
5. Conveyor
6. Winding station
  - 6.1 Winding of rubber canvas/rubber lining
  - 6.2 Unwinding of lining

### Main technical characteristics:

Purpose: Increase of width and thickness of rubber canvas and rubber lining

Width:  $-A \leq 2000\text{mm}$   
 $-A_1, A_2 (800 \pm 1200)\text{mm}$

Thickness:  $-(\delta_1 + \delta_2) \leq 12\text{mm}$

Work speed:  $v = (5 \pm 12)\text{m/min}$

Laterally movement of stations 2 i 6..... $\pm 80\text{mm}$

Total power:  $\approx 15\text{kW}$